



E1E21

E1E22

E1E23

SILICONE RUBBER / SPECIAL ELECTRONICS

Natural frequency : (1)
20 to 25 Hz

DESCRIPTION

- VHDS elastomer.
 - Flange and shaft in 18/8 stainless steel.
- Two Ø C fail safe rings must be provided.

APPLICATIONS

- Protecting electronic equipment, navigation equipment, instrument panels, measuring instruments, control panels on aircraft, road vehicles and railway trains.

CHARACTERISTICS

Natural frequency :

- axial : 15 to 25 Hz;
- radial : 20 to 35 Hz.

Maximum permitted excitation at natural frequency of suspension : ± 0.5 mm.

Amplification factor at resonance < 4.

Operating temperature : - 54°C to + 150°C.

Structural strength corresponds to a continuous acceleration of 10 g at maximum load.

Maximum axial travel available for shock :

E1E21 : ± 6 mm / E1E22 : ± 8 mm for f min

Weight : E1E21 : 9 g / E1E22 : 25 g / E1E23 : 63 g.

These mounts meet the standard AIR7304 curve ZF

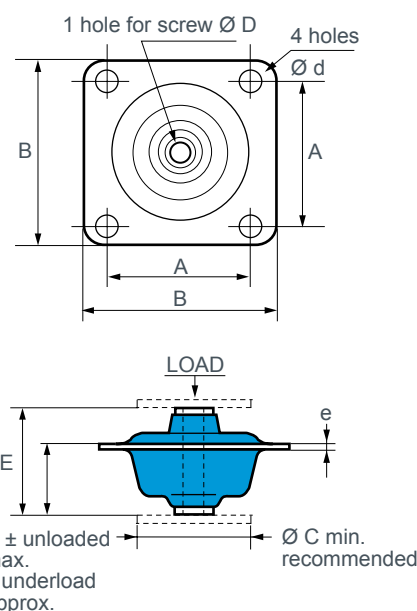

Reference *	A (mm)	B (mm)	Ø C (mm)	D	E (mm)	Ø d (mm)	e (mm)	H (mm)	h (mm)
E1E21S□□AL	25,4	32	24	M4	19	3,6	0,8	12,5	11
E1E22S□□AL	34,9	44,5	28	M5	25,4	4	1,5	16,5	15
E1E23S□□AL	49,2	60,5	42	M6	36	5	2	22	20

* Exist with a diamond flange (BL)

Reference	Range of use (daN)	Frequency (Hz)	Range of use (daN)	Frequency (Hz)
E1E21S38AL E1E21S63AL E1E21S77AL	0,10 - 0,40 0,20 - 0,90 0,26 - 1,20	15 - 25	0,10 - 0,15 0,20 - 0,30 0,26 - 0,40	20 - 25
E1E22S38AL E1E22S63AL E1E22S77AL	0,20 - 1,00 0,40 - 1,70 0,50 - 2,20	12 - 25	0,20 - 0,40 0,40 - 0,70 0,50 - 0,90	12 - 25
E1E23S42AL E1E23S77AL	0,40 - 1,20 1,00 - 2,90	10 - 15		

1) the indicated natural frequency, are valid for the maxi loads of the ranges of use quoted in the paragraph : TECHNICAL CHARACTERISTICS.